

# On-Line CardioTheater Instruction Manual for Amplifier Models 800 and 1600 (wired)



Full installation instructions accompany your Cardio Theater equipment order. This On-Line version of our Installation/Instruction Manual is included in our web site for your convenience. If you have any questions regarding your installation that are not covered by this Manual or by our Troubleshooting Guide, please contact our [Service Department](#):

Cardio Theater Inc.  
Service Department  
Telephone: 1-800-776-6695  
E-mail: [service@cardiotheater.com](mailto:service@cardiotheater.com)

## Table of Contents

(Click to jump to the page you want to see.)

- [Before you begin](#)
- [Important Safeguards](#)
- [Suggestions for Installation](#)
- [Installation: Controls and Indicators](#)
- [Installation: System Connections](#)
- [Installation: Attaching Upper Monitors](#)

- Setup and Operation: Input Signal Setup
  - Setup and Operation: Upper Monitor Operation
  - Specifications
- 

## Before You Begin

Please insure that you have all of the required equipment before disposing of any packing materials.

### Equipment List:



Model 800 or 1600 Amplifier



Upper Monitors,  
quantity as ordered

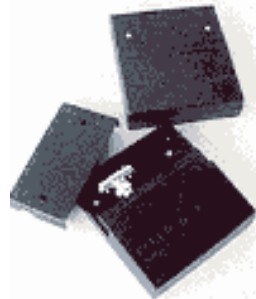

Floor Monitors,  
quantity equal to Uppers

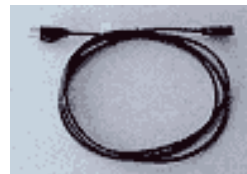

Power Cord,  
quantity (1)

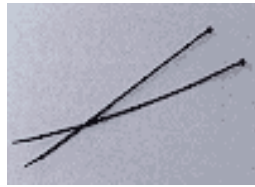

Plastic wire ties;  
(4) for each Upper Monitor



Terminators,  
(2) with Model 800 Amp or  
(4) with Model 1600 Amp



Coiled Cables;  
(1) for each Upper Monitor



"T" Connectors;  
(1) for each Floor Monitor



BNC Bullet Connectors;  
(2) with Model 800 Amp or  
(4) with Model 1600 Amp



Coax Cable;  
(1) for each Floor Monitor

[Click here to go back to the Index.](#)

## Important Safeguards

Please read all of these safeguards before operating the unit. Follow all warnings placed on the unit and adhere to the operating and use instructions. Retain your manual for future reference.

**1. Power sources** - Connect the unit to a power source only of the type described in the operating instructions or as marked on the appliance.

**2. Power cord protection** - Route all power-supply cords so that they are not walked on or pinched by items placed upon or against

them.



**3. Grounding** - Take precautions so that the grounding or polarization means of the unit are not defeated.

**4. Ventilation** - Position the unit so that its location does not interfere with ventilation. To maintain good ventilation, do not put items on or over the unit. Do not use the unit on a cushioned surface that may block the ventilation openings.



**5. Water and moisture** - Do not locate the unit near

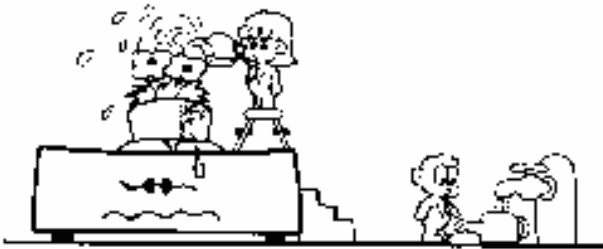

water.

**6. Temperature** - The unit may not function properly if used at extreme temperatures. The ideal temperature is 41°F (5°C) to 87°F (30°C)

**7. Heat** - The unit should be located away from heat sources such as radiators, heat registers, stoves, etc.

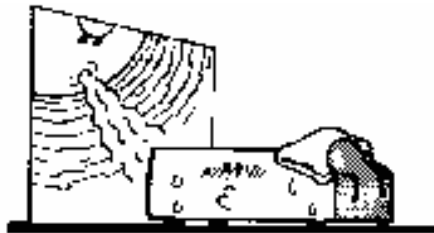

**8. Electric shock** - Care should be taken so that objects do not fall and liquid is not spilled on the enclosure. If a metal object, such as a hairpin or a needle, comes in contact with the inside of this unit, a dangerous electric



shock may result.

**9. Enclosure removal** - Never open the enclosure. If the internal parts are accidentally touched, a serious shock may occur.



**10. Cleaning** - Do not use solvents such as alcohol; paint thinner, etc. to clean the unit. Use a clean dry cloth.



**11. Abnormal smell** - If an abnormal smell is detected, immediately turn the power OFF and disconnect the power cord. Contact your dealer or service center.



**12. Stands** - Any component should be moved with care. Quick or excessive force could cause the stand to overturn.



**13. Nonuse periods** - The power cord should be disconnected when left unused for a long period of time.

**14. Damage requiring service** - The unit should be serviced by a qualified technician when:

- A. The power supply cord or the plug has been damaged;
- B. Objects have fallen, or liquid has been spilled into the unit;
- C. The unit has been exposed to rain;
- D. The unit does not appear to operate normally or exhibits a marked change in performance; or
- E. The unit has been dropped, or the enclosure damaged.

**15. Servicing** - The user should not attempt to service the unit beyond that described in this manual. All other servicing should be referred to a qualified technician.

## Safety Precautions

**WARNING:** To prevent fire or electric shock, do not expose this appliance to rain or moisture.

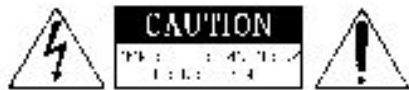

**Caution:** If you see this symbol, be aware of its meaning: To reduce the risk of electric shock, do not remove the cover or back of the unit. No user-serviceable parts are inside. Refer servicing to a qualified technician.



This symbol is intended to alert the user to the presence of uninsulated "dangerous voltage" within the product's enclosure that may be of sufficient magnitude to constitute a risk of electric shock to persons.



This symbol is intended to alert the user to the presence of important operating and maintenance instructions in the literature accompanying the unit.

[Click here to go back to the Index.](#)

---

# Suggestions for Installation

## General Suggestions

- **Provide for cable or an antenna for radio and television reception. The type of building and the location could effect reception.**
- **Use televisions with "Audio Out" or preferably "Line Out." If you are using televisions with "Audio Out" the external speakers should be turned off and the volume set to the highest level.**
- **Televisions should be arranged so that every user has a clear view of all televisions. Stagger the rows of cardio equipment placing shorter pieces (e.g., recumbent bikes) in front and taller pieces (e.g., steppers) toward the back.**
- **Tuners or receivers may be used. If you are using a receiver, DO NOT use the speaker out connections as this may damage the equipment. Instead use the "Record Out" or "Line Out."**
- **Group the audio components in a single location to minimize cabling.**
- **If the audio components are stacked in a stereo cabinet insure there is adequate ventilation. The Cardio Theater Amplifier requires a minimum one inch (1") clearance on both sides for ventilation.**

### Main Amplifier:

- Place the Main Amplifier in a well ventilated area with the front and back easily accessible.
- Number the audio components to match corresponding channel selections on the Upper Monitors.
- Label cables as you connect them to the Main Amplifier. This will avoid any guess work in the future.

### Upper Monitors:

- When mounting Upper Monitors to equipment, take care not to interfere with the normal operation of the equipment.
- Likewise, the Coiled Cable connecting the Upper Monitor to the Floor Monitor should not interfere with normal operation of the cardiovascular piece.
- If mounting the Upper Monitor to a control panel, avoid covering controls or indicators.

### Floor Monitors:

- Floor Monitors should be secured to the floor, or in a sub floor. DO NOT attach the floor monitor to the cardiovascular piece. This will cause problems when machines are moved (i.e., elevating treadmills), or for cleaning.
- Floor Monitors may be screwed down using the mounting holes or adhered to the floor using a strong double-sided cloth tape.

### Cabling and Connectors:

- DO NOT SUBSTITUTE ANY TYPE OF CABLE OR CONNECTOR OTHER THAN THAT SPECIFIED BY THE MANUFACTURER.
- The Coax Cabling and the Floor Monitors can be installed under the floor, either in a sub floor or in a conduit. In lieu of a sub floor or conduit, use an above-floor conduit system to protect the cabling, such as a rubber raceway.
- The most predominant method of covering the Coax Cable above floor is a rubber raceway molding (Wiremold catalog number 1500). It is a narrow cable cover with beveled edges and a low profile that will not interfere with traffic flow. It may be secured to the floor with double-sided cloth carpet tape, screws, or nails. Wiremold catalog number 1500 may be purchased from Cardio Theater at (800) CARDIO-1, or (678) 686-4700.
- There are four (4) output connectors on a 16-channel Amplifier and two (2) on an 8-channel Amplifier. Use all four (or two) and divide the Upper Monitors evenly among them. For example: if you have 20 Upper Monitors on a 16-

channel system, connect 5 Upper Monitors to each of the output connectors.

- The maximum total length of the Coax Cables connected to any one output is 400 feet.
- A maximum of 20 Upper Monitor sets can be connected on a single Coax line.
- The system is designed to work with the monitor boxes connected in a daisy-chain or serial configuration.
- **DO NOT CREATE BRANCHES OFF A MAIN LINE!** See drawing below:

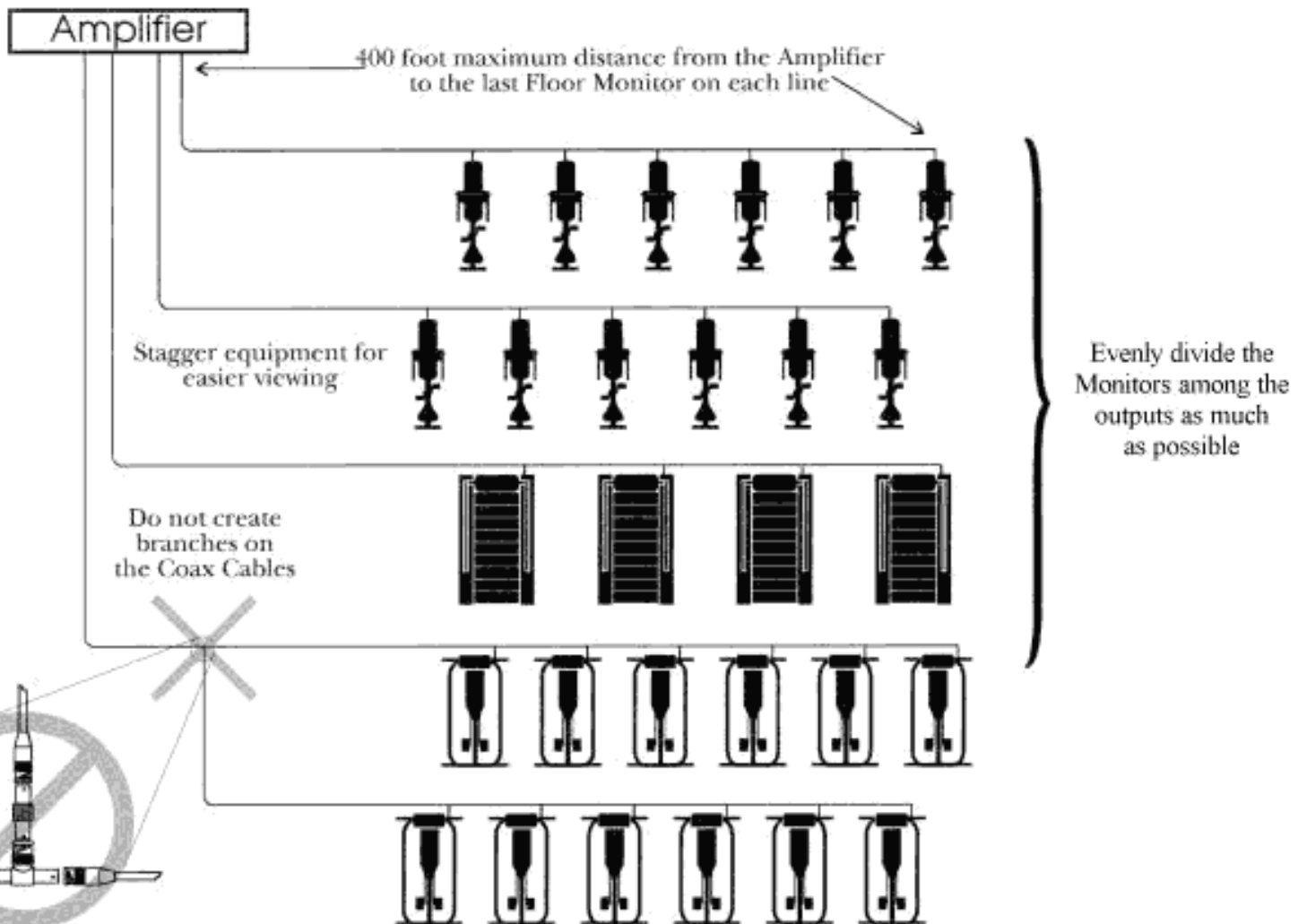

[Click here to go back to the Index.](#)

## Controls and Indicators



# Distribution Amplifier - Front

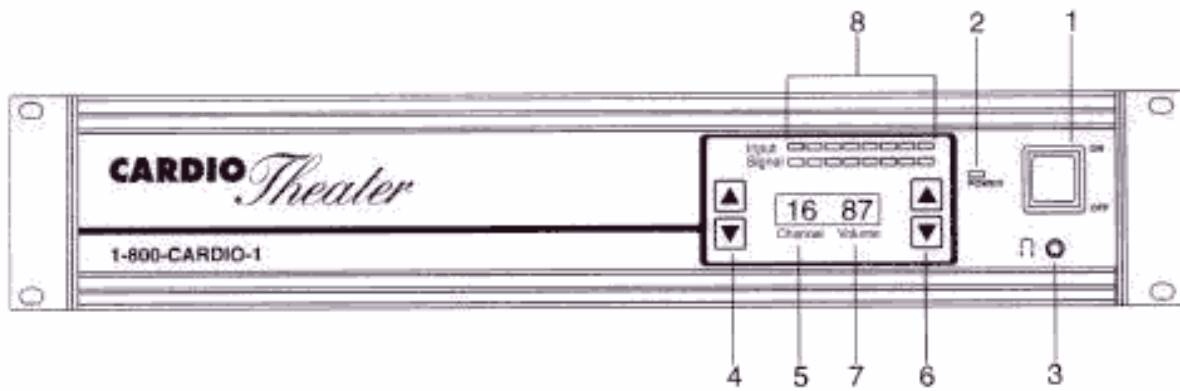

## Legend for Distribution Amplifier - Front

### 1. Main power switch

The main power switch supplies power for the main amplifier and all monitor boxes.

### 2. Power-on Indicator

Lights when main power switch is on.

### 3. Phone Jack

For setting input volume levels.

### 4. Channel Select

For setting desired channel while adjusting input levels.

### 5. Channel Indicator

Indicates current channel.

### 6. Input Volume Select

Indicates the input volume for the currently selected channel.

### 7. Input Volume Level

Indicates the input volume for the currently selected channel.

## 8. Bar Graph Meter

Graphic display of input volume signal.



# Distribution Amplifier - Back

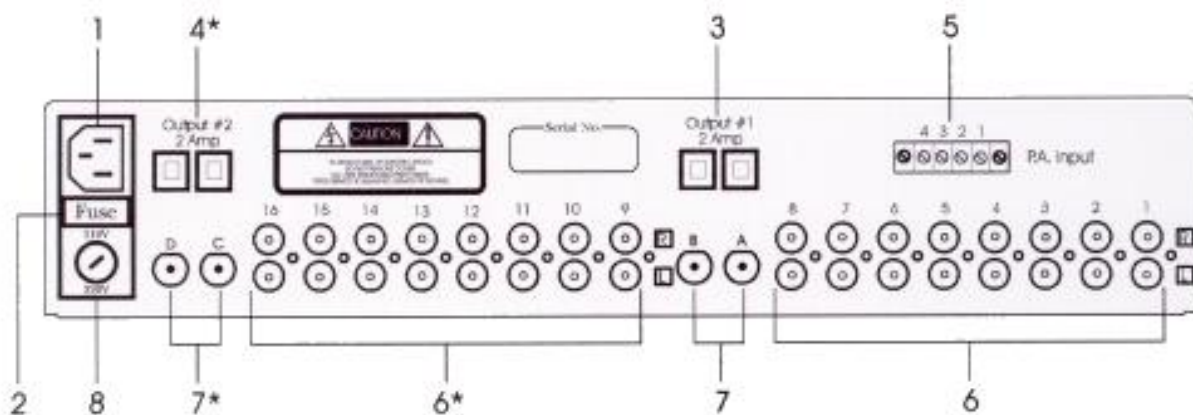

\* Items found on model 1600 only.

## Legend for Distribution Amplifier - Back

### 1. Power Input Connector

The power input connector brings 110 Vols 60 Hz AC into the system.

### 2. Main Line Fuse

Main system fuse for the amplifier and all monitor boxes, 2 Amp 250 Volt Slow-Blow.

### 3. Output #1 Circuit Breaker

Power to output connectors A & B, 2 Amp.

### 4. Output #2 Circuit Breaker

Power to output connectors C & D, 2 Amp.

### 5. P.A. (Public Address) Input

External paging system tie-in.

## 6. Audio Inputs

channel 1 - 16 audio inputs (1 - 8 on an 8 channel amplifier)

## 7. Output Connectors

Output connectors to monitor boxes.

## 8. Input Voltage Selector

Selects input voltage between 110VAC or 220VAC.



# Upper Monitor

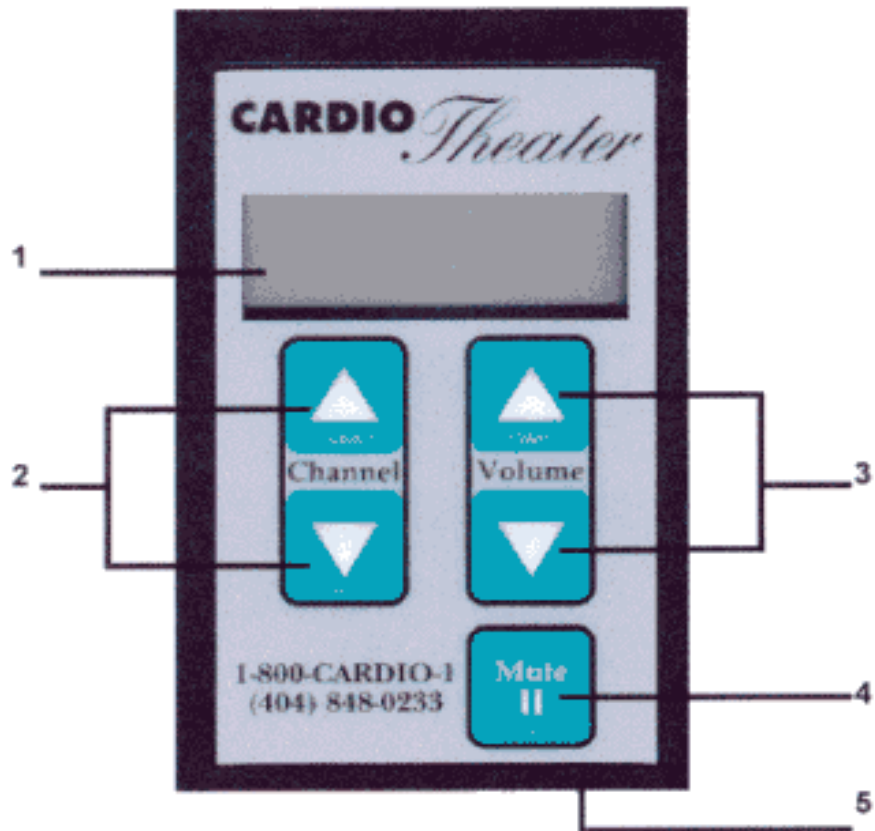

## Legend for Upper Monitor

### 1. Channel Display

Indicates current channel selected

### 2. Channel Select

To select the desired listening channel

### 3. Volume Adjust

To select the desired listening volume.

### 4. Mute

Audio mute.

### 5. Headphone Jack

Standard 3.5 mm headphone jack.



## Floor Monitor



## Legend for Floor Monitor Box

### 1. Phone Jack

Connector for Coiled Cable to Upper Monitor.

## 2. BNC Connector

Connector for attaching Coax Cable to Floor Monitor.

[Click here to go back to the Index.](#)

# System Connections

## Distribution Amplifier

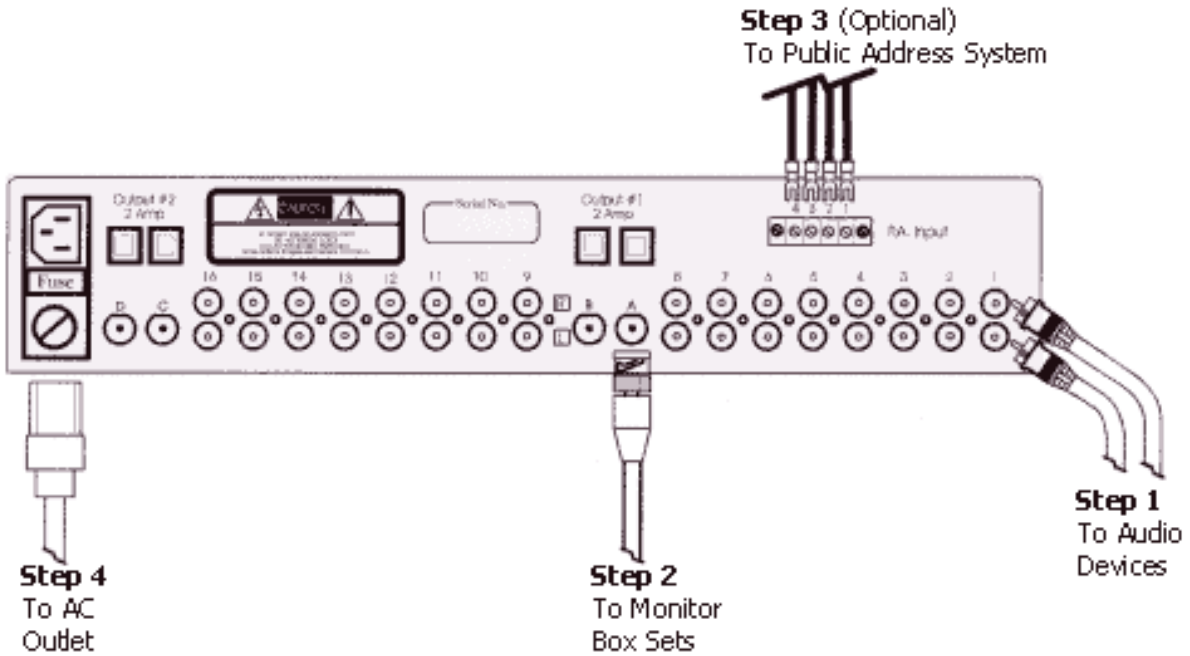

**NOTE: MAKE ALL CONNECTIONS TO MAIN AMPLIFIER, UPPER MONITORS & AUDIO DEVICES WITH POWER OFF.**

<p><b>Step 1</b></p>	<p>Connect the audio components:</p> <ul style="list-style-type: none"> <li>● to inputs 1 through 16 for a 16-channel Amplifier; <i>or</i></li> <li>● to inputs 1 through 8 for an 8-channel Amplifier.</li> </ul>
<p><b>Step 2</b></p>	<p>Connect the Coax Cable to outputs A,B,C, and D.</p> <ul style="list-style-type: none"> <li>○ A maximum of 20 Upper Monitors can be connected to a single output.</li> <li>○ For systems using multiple outputs, we recommend connecting as follows: <ul style="list-style-type: none"> <li>1 Cable to output A</li> <li>2 Cables to A &amp; C</li> <li>3 Cables to A, B, &amp; C</li> <li>4 Cables to A, B, C, &amp; D</li> </ul> </li> <li>○ For a more balanced system, evenly divide the Upper Monitors among the four outputs (two outputs on an 8 channel system). For example: On a system with 40 Upper Monitors, install 10 on each Coax Line (20 on each Coax Line for an 8 channel system).</li> </ul>
<p><b>Step 3</b></p>	<p>Connect to the optional Public Address input as follows:</p> <ul style="list-style-type: none"> <li>● Terminals #1 and #2 to the activation switch on the PA.</li> <li>● Terminals #3 and #4 are line level from the PA System.</li> </ul>
<p><b>Step 4</b></p>	<p>Use the power cord supplied to connect Main Amplifier to a 110 or 220 Volt AC outlet as applicable.</p> <ul style="list-style-type: none"> <li>● <b>CAUTION: Before connecting to 220 volt outlet be sure voltage selector on back of amplifier is set to 220. (<a href="#">See "Distribution Amplifier - Back"</a>)</b></li> </ul>



## Upper Monitors and Floor Monitors

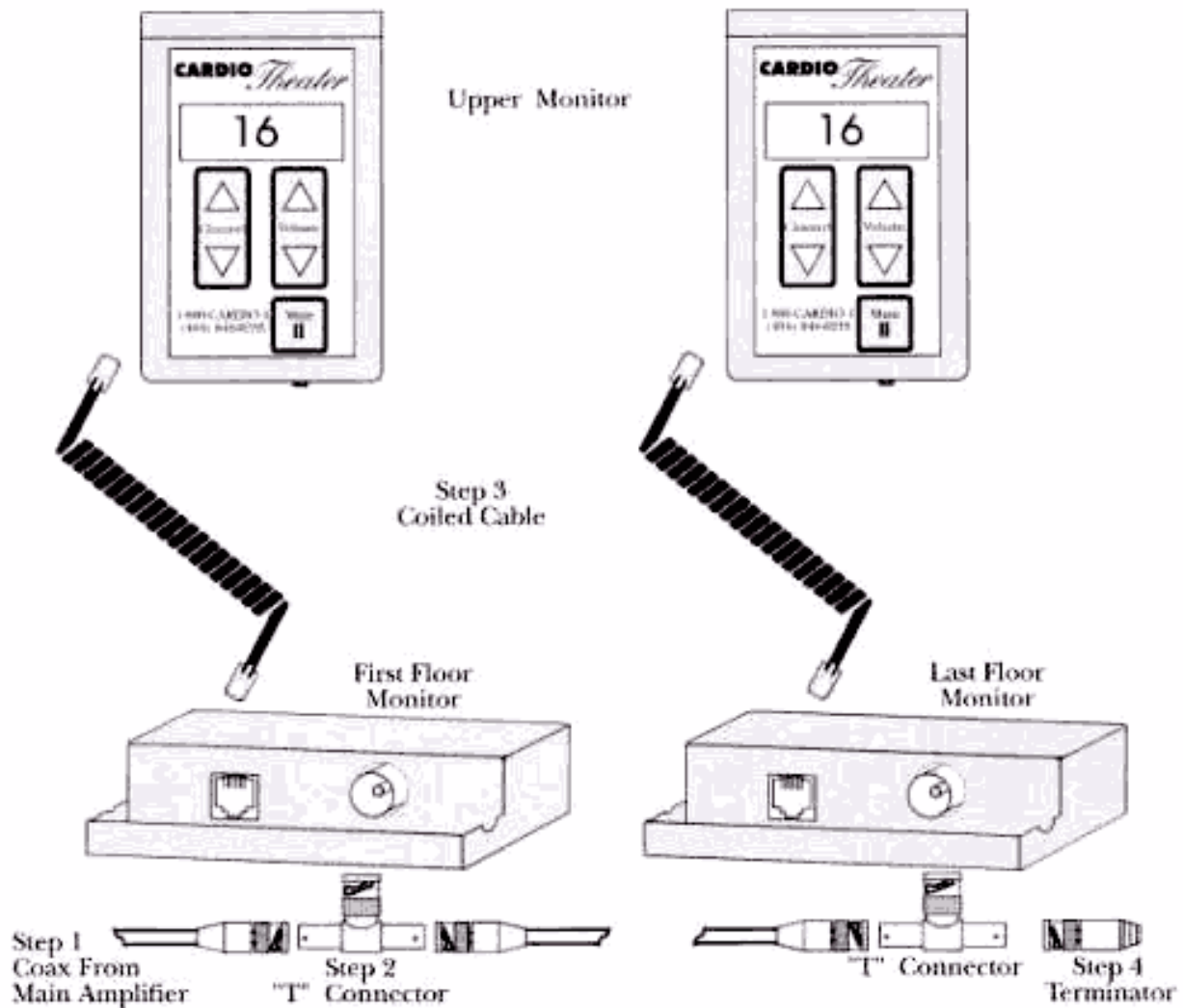

<b>Step 1</b>	From the Main Amplifier, connect the Coax Cable to as many as 20 Floor Monitors using the Coax Cable and "T" Connectors supplied, as shown above.
<b>Step 2</b>	Connect the "T" Connectors at each location to the Floor Monitor.
<b>Step 3</b>	Use the Coiled Cables to connect each Floor Monitor to an Upper Monitor. Note: The plug for the Coiled Cable is on the back of the Upper Monitor.
<b>Step 4</b>	On the last "T" Connector of each run of Coax Cable, a Terminator (supplied with this system) must be installed for proper operation.

# Attaching Upper Monitors

**The Upper Monitor can be installed on any piece of equipment.**

**For equipment with round handles or railing, Upper Monitors are supplied with a build-in mounting block.**

- Align the Upper Monitor on the handle or rail as desired.
- Use two of the supplied Plastic Wire Ties to attach the Upper Monitor to the handle or rail.
- Pull wire ties firmly to secure.

This method is the preferred method of attaching the Upper Monitor to minimize interference with control panels and displays.

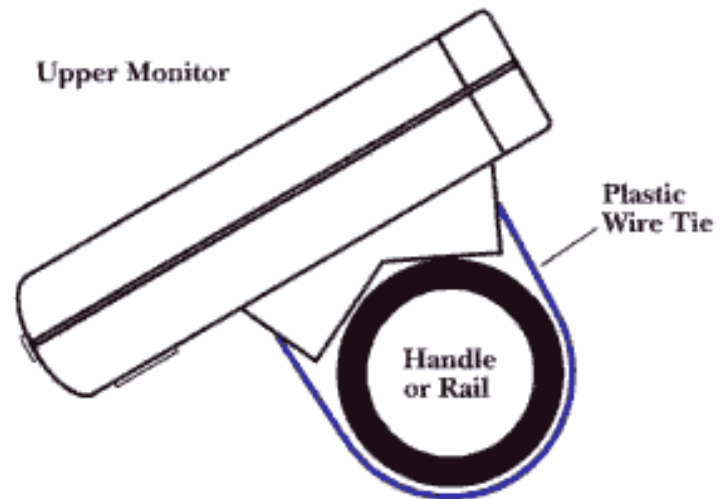

**For equipment with flat control panels but no hand rails, SuperLock (a form of super strong velcro) may be used.**

- Determine the best mounting position.
- Clean the mounting surface thoroughly.
- Remove the protective cover from the adhesive strip.
- Position the Upper Monitor and press firmly for the adhesive to grip.

**CAUTION:** When attaching to a control panel, care should be taken to avoid blocking access to controls or illustrations.

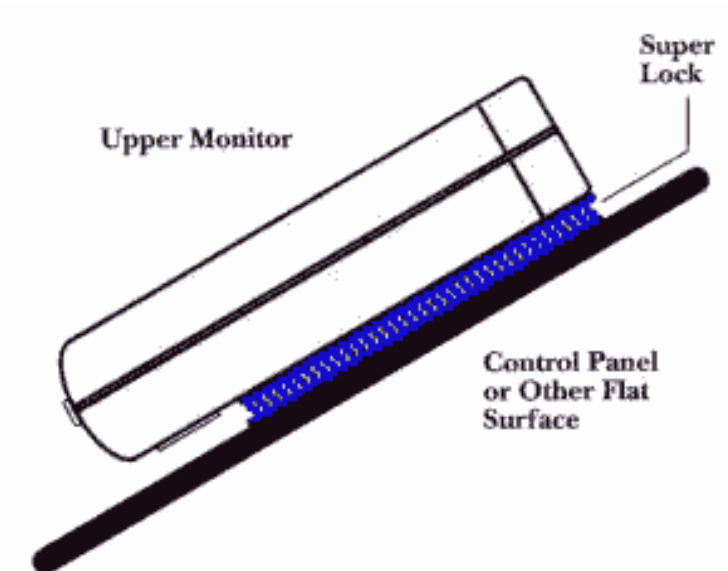



# Setup and Operation

## Input Signal Setup

**This procedure will adjust the audio level entering the Amplifier for each audio component connected.**

**Step  
1**

When installation is complete, turn power on at the Main Amplifier and all audio components. The Power LED and Input Signal Bar Graph will light for 5 seconds while the display shows the version number.

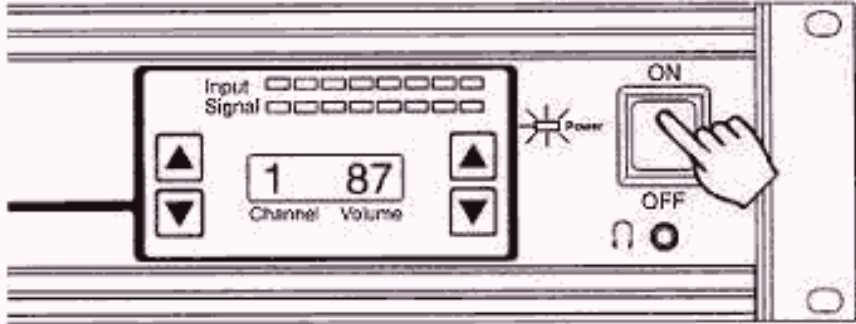

**Step  
2**

Plug headphones into the phono jack located under the Main Power Switch.

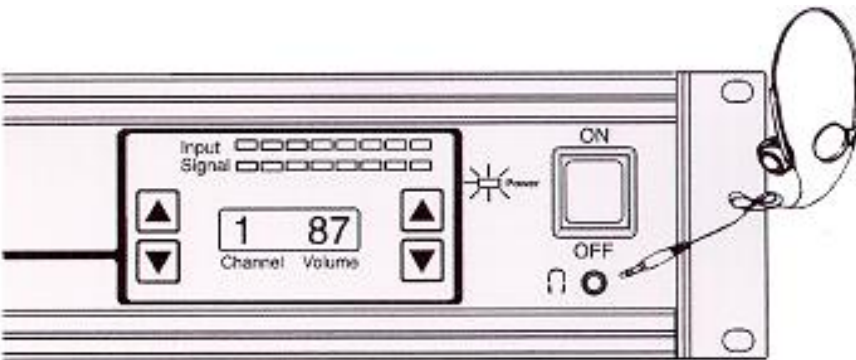

**Step  
3**

Use the Channel Select buttons to select the desired channel to be adjusted (left side of display). If the channel selected has little conversation or a soft passage in a song, wait for a normal signal before proceeding.

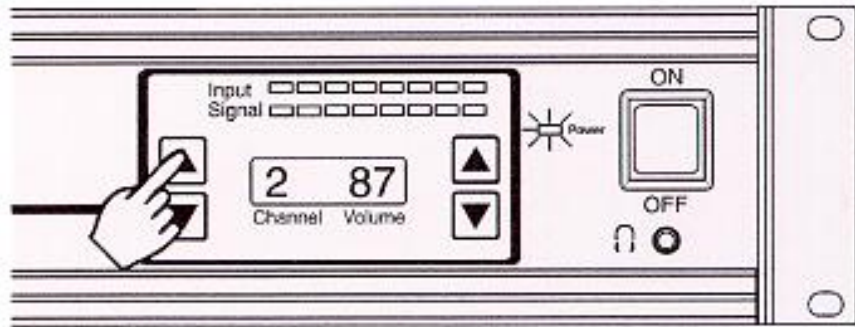

**Step  
4**

Use the Input Volume Select buttons to adjust the input volume level (right side of display). While observing the Input Signal Bar Graph, adjust the input volume level as high as possible **without lighting the red LEDs**. Observe the setting for approximately 30 seconds with a normal volume signal to insure

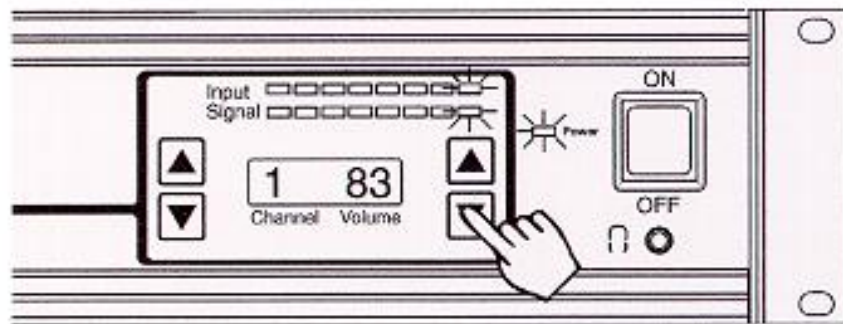

proper setup.

**Step  
5**

Repeat steps 3 and 4 for each remaining channel.

**Caution: turning up the volume level too high will cause distortion (poor sound quality) at the monitor boxes. These settings are automatically set in memory and retained when power is turned off.**

[Click here to go back to the Index.](#)

## Setup and Operation (Continued):

### Upper Monitor Operation

**Channel  
Select**

Press Channel Select buttons for desired channel selection (left side of display). Press and hold either button to scroll through channels rapidly.



## Volume Adjust

Press Volume Adjust buttons for desired listening volume. Press and hold either button to adjust volume rapidly. Volume automatically resets to a default volume when headphones are unplugged.

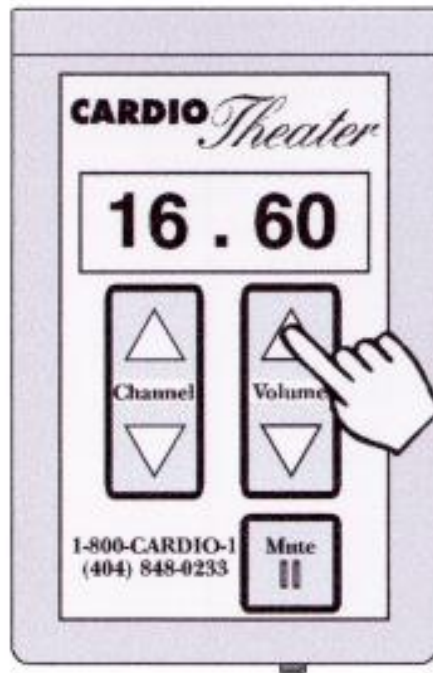

## Mute

Press Mute button to turn audio volume on or off. Mute automatically resets when headphones are unplugged.

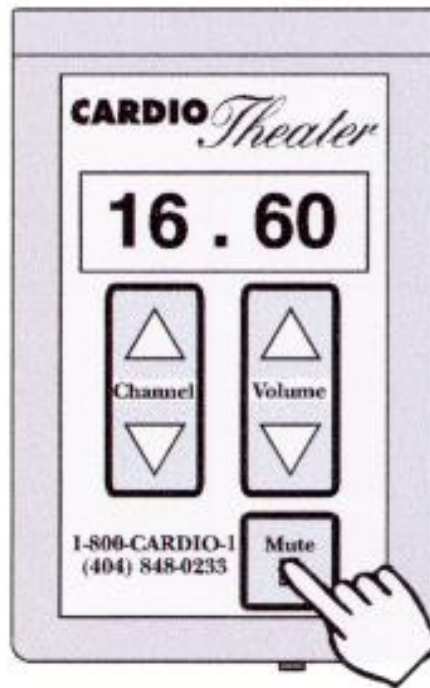

[Click here to go back to the Index.](#)

# Specifications

## Main Amplifier

### Input Sensitivity/ Impedance

Maximum..... 3.5Vrms / 30k ohm  
Minimum..... 100mVrms / 30 k ohm  
Gain Control Range..... 31db

Power Consumption..... 610 Watt Max

### Dimensions

Width ..... 19.00" / 483 mm  
Height ..... 3.87" / 98 mm  
Depth ..... 14.75" / 375 mm

### Weight

Model 800 ..... 11 lb. / 5 Kg  
Model 1600 ..... 17 lb. / 7.7 Kg

## Floor Monitor

### Dimensions

Width ..... 4.52" / 114.8 mm  
Height ..... 1.21" / 30.7 mm  
Depth ..... 4.85" / 123.2 mm

Weight..... 6.5 oz. / 184 g

## Upper Monitor

Output Level / Load Impedance..... 550mV / 32 Ohm

### Dimensions

Width ..... 2.55" / 64.8 mm  
Height ..... 3.93" / 99.8 mm  
Depth ..... 0.97" / 24.6 mm

Weight..... 3 oz. / 83 g

## Cabling

**Coaxial Cable**

**Size ..... RG58**

**Connectors ..... BNC Male**

**Coiled Cable**

**Type..... 6 Conductor, Coiled Phone**

**Connectors..... RJ11, 6 Position 6 Fill, Pinned 1 to 1**

**[Click here to go back to the Index.](#)**

**Note: Cardio Theater Inc. follows a policy of continuous advancements in development. For this reason specifications may change without notice. For questions regarding any specifications, please call the Service Center at (800) 776-6695.**